

Features

- 808nm center wavelength
- 0.15 or 0.22NA 105µm core multimode fiber pigtail
- Uncooled
- Laser welded and epoxy free
- Hermetically sealed
- Built in thermistor
- Telcordia GR-468 Core / MIL-Std 883 compliant

Applications

- Fiber lasers
- Yb laser pumping
- Defense
- Life Science

General Description

The EM4 high power laser has a fiber coupled output power of typical 3W. The module is ideal for use in a variety of applications where brightness is essential with a reliable and robust packaging. The module is hermetically sealed into an 8 pin butterfly metal ceramic package and contains a thermistor for temperature monitoring. The module is pigtailed using a step index fiber with a 0.15 or 0.22 numerical aperture, 105 micron core diameter.

Absolute Maximum Ratings

Stresses beyond those listed under "Absolute Maximum Ratings" may cause permanent damage to the device. These are stress ratings only and operation of the device at these or conditions beyond these are not implied. Exposure to absolute maximum ratings for extended periods of time may affect device reliability.

Parameter	Sym	Condition	Min	Max	Unit
Storage Temperature	T _{STG}		-40	85	°C
Operating Case Temperature	T _{OP}		-20	70	°C
Laser Forward Current	I _F			4.7	A
Laser Reverse Voltage	V _R			2	V
Thermistor Current				2	mA
Thermistor Voltage				5	V
Fiber Pull Force				5	N
Fiber Bend Radius			35		mm
Lead Soldering Time				10	s
Lead Soldering temperature				250	°C
ESD		HBM		500	V

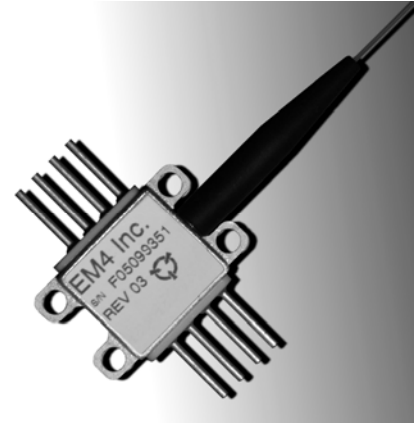

Ordering Information

Part	λ _C [nm]	Fiber NA	Monitor Detector
EM340	808	0.15	-
EM341	808	0.22	-
EM342	808	0.15	Yes
EM343	808	0.22	Yes

For pricing and delivery information, please contact EM4 inc. direct at +1 781 275 7501, sales@em4inc.com or any of the representatives listed at www.em4inc.com.

The information published in this datasheet is believed to be accurate and reliable. EM4, Inc. reserves the right to change without notice including but not limited to the design, specification, form, fit or function relating to the product herein. ©2004 EM4, Inc. All rights reserved.



3W 808nm 8 Pin Multimode Pump Laser

Optical And Electrical Characteristics

T_C=25°C unless otherwise specified, good thermal contact

Parameter	Sym	Condition	Min	Typ.	Max	Unit
Center Wavelength	λ_C			808		nm
Operating Current	I _{OP}	P=P _{OP}			4.5	A
Operating Voltage	V _{OP}	I=I _{OP}			2.2	V
Output Power	P _{OP}		3			W
Threshold Current	I _{TH}			0.85		A
Wavelength Drift vs. T _C	$\delta\lambda/\delta T_C$			0.2		nm/°C
Spectral Width	$\Delta\lambda$	17dB down from peak		6		nm
Operating Case Temperature	T _C		0		45	°C
Thermistor Resistance	R _{TH}	T=25°C	9500	10000	10500	Ω
Thermistor β coefficient	β	0 / 50°C		3892		

Fiber Specification

Parameter	Sym	Condition	Min	Typ.	Max	Unit
Fiber Type			Step Index			
Jacket Material			PVDF			
Numerical Aperture		EM340, EM342		0.15	0.17	
		EM341, EM343		0.22	0.24	
Core Diameter			102	105	108	μm
Cladding Diameter			123	125	128	μm
Buffer Diameter			235	250	265	μm
Jacket Diameter				900		μm
Jacket Length From End Of Boot			75		95	mm
Pigtail Length			1			m

For pricing and delivery information, please contact EM4 inc. direct at +1 781 275 7501, sales@em4inc.com or any of the representatives listed at www.em4inc.com.

The information published in this datasheet is believed to be accurate and reliable. EM4, Inc. reserves the right to change without notice including but not limited to the design, specification, form, fit or function relating to the product herein. ©2004 EM4, Inc. All rights reserved.

Typical Operating Characteristics

T_c=25°C

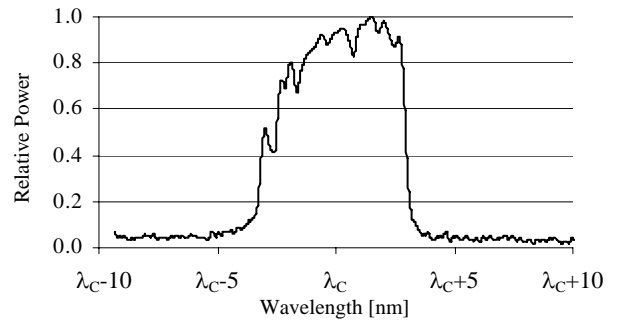
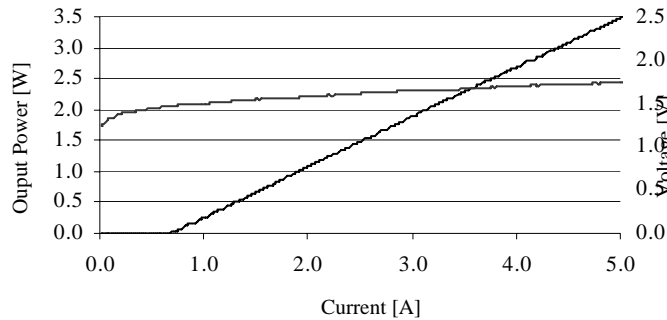

Mechanical Drawing

All units in mm

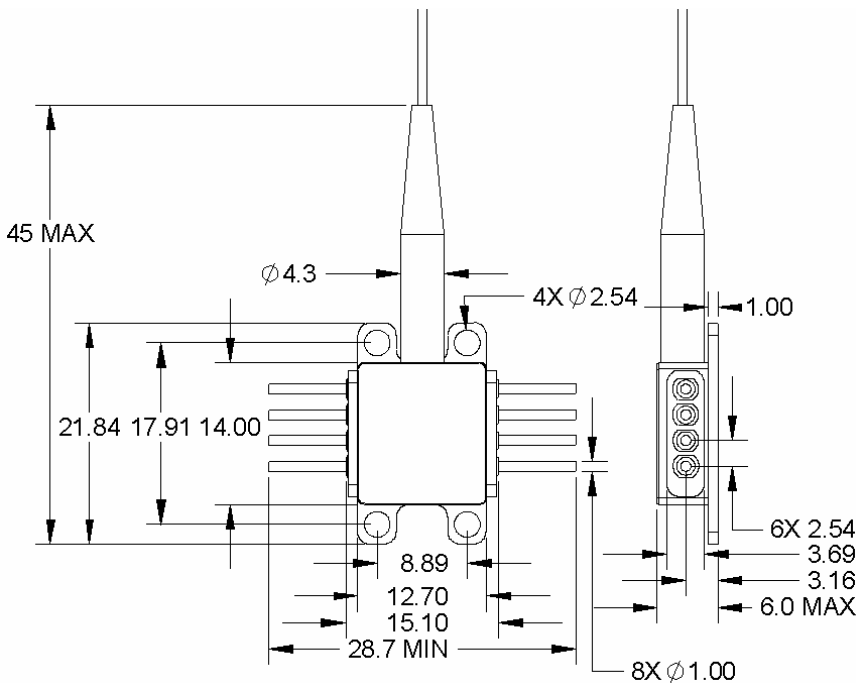

Pinning

Pin	Part Number	Description
1	All	Thermistor
2	All	Thermistor
3	EM340, EM341	NC
	EM342, EM343	Monitor Anode
4	EM340, EM341	NC
	EM342, EM343	Monitor Cathode
5	All	Laser anode (+)
6	All	Laser cathode (-)
7	All	NC
8	All	NC

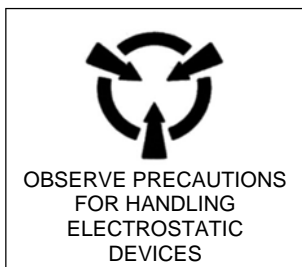

The component complies with all applicable portions of 21 CFR 1040.10, 21 CFR 1010.2 and 21 CFR 1010.3. Since this is a component, it does not comply with all of the requirements contained in 21 CFR 1040.10 and 21 CFR 1040.11 for complete laser products.

For pricing and delivery information, please contact EM4 inc. direct at +1 781 275 7501, sales@em4inc.com or any of the representatives listed at www.em4inc.com.

The information published in this datasheet is believed to be accurate and reliable. EM4, Inc. reserves the right to change without notice including but not limited to the design, specification, form, fit or function relating to the product herein. ©2004 EM4, Inc. All rights reserved.